

Euromaid

User Manual

Wine Chiller
EWC122IB

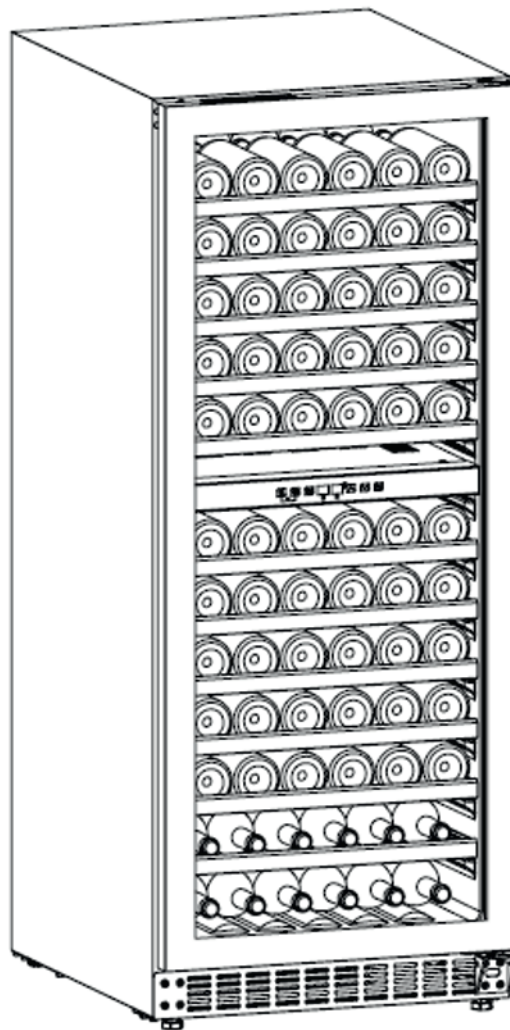

Thank you for purchasing and using this Euromaid wine chiller. Our wine chillers and beverage centres are will create the perfect environment to store and display your collection of wine and beverages.

Contents	
Safety instructions & warnings	Page 4 - 6
Installation	Page 7
Description of the appliance	Page 8 - 10
Operation	Page 10 - 12
Troubleshooting	Page 13
Maintenance and cleaning	Page 14
Technical parameters	Page 15
Manufacturer Guarantee	Page 16 - 17

Safety instructions & warnings

Your safety is of the utmost importance to our company. Please make sure that you read this instruction booklet before attempting to install or use the appliance. If you are unsure of any of the information contained in this booklet, please contact the Technical Department.



Prohibition



Warning



Caution

Caution

- This appliance can be used by children aged from 8 years and above and persons with reduced physical, sensory or mental capabilities or lack of experience and knowledge if they have been given supervision or instruction concerning use of the appliance in a safe way and understand the hazards involved. Children should not play with the appliance. Cleaning and user maintenance should not be performed by children without supervision.
- Children aged from 3 to 8 years are allowed to load and unload refrigerating appliances. Children should be supervised to ensure that they do not play with the appliance.
- This appliance is intended for HOUSEHOLD USE ONLY and not for commercial or industrial use.

Warning

- Keep ventilation openings in the appliance enclosure or in the built-in structure clear of obstruction.
- Do not use mechanical devices or other means to accelerate the defrosting process, other than those recommended by the manufacturer.
- Do not damage the refrigerant circuit.
- Do not use electrical appliances inside the storage compartments of the appliance, unless they are of the type recommended by the manufacturer.

- Make sure that the appliance is connected to power supply in accordance with the rating label.
- Use an independent grounded socket with 10A or higher, do not connect to transformer or socket with multiple outlets.
- Make sure socket is grounded properly and do not modify power cord & plug.
- Connect power plug with socket firmly in case of possible risk of fire.
- Plug should be placed within reach for easy disconnection after the appliance positioned in case of accidents occurring.
- Do not store or burn gasoline or other inflammables near the appliance in case of possible fire.
- Do not store inflammables, explosives, acid & alkaline liquids etc.in the compartment of the appliance.
- Do not operate other appliances in the compartment.

Child Safety

- Do not allow children to play inside the appliance in case of entrapment.
- Do not allow children to hang on the door or play with appliance.
- Do not allow children to reach into compressor compartment or touch metal components at rear of the appliance in case of possible injury.

Keep away from water

- Do not spray water on the appliance or wash the appliance by pouring or filling with water in case of invalid insulation and possible electric shock.

Be careful of freezing

- Do not touch surface of the liner inside the compartment, especially with wet hand, in case of frozen injury while the appliance is in operation.

Do not open the door for long periods

- Opening the door for long periods can cause a significant increase of the temperature in the compartments of the appliance.

Modification on the appliance not allowed

- Do not attempt to modify the appliance by yourself as this may cause damages to the appliance.

Unplug the appliance under certain conditions

- Unplug the appliance before cleaning & maintenance.
- Unplug the appliance when a power cut has occurred.

Disposal of the appliance

- Please adhere to local regulations regarding disposal of the appliance for its flammable refrigerant and blowing gas.
- Before you scrap the appliance, please take off the doors to prevent children being trapped inside.
- Send the appliance to a designated disposal location.

Prohibition

Do not damage the power cord

- Do not disconnect the appliance by pulling power cord rather than pulling the plug.
- Do not place the appliance on top of the power cord or step on the cord intentionally.
- Put the power cord in the right place when moving the appliance.

When the power cord is damaged

- Do not use damaged power cord, and get it replaced immediately by manufacturer service agent or by a qualified electrician.
- If needed, extend the power cord with cord of 0.75mm² or bigger by a qualified electrician.

Installation

Position

- ⚠ Do not lean the appliance over 45°, especially when moving it.
- ⓘ The appliance must be put on flat, firm & dry floor or similar noncombustible pad; do not use the package foam pad.
- ⊘ Do not put the appliance in a wet place.
- ⊘ Do not use the appliance in a frozen place.
- ⊘ Do not use the appliance outdoor in case of sunlight or rain.

The appliance is designed to either build in the cabinet or stand alone on the floor.

Demonstration for building in the cabinet:

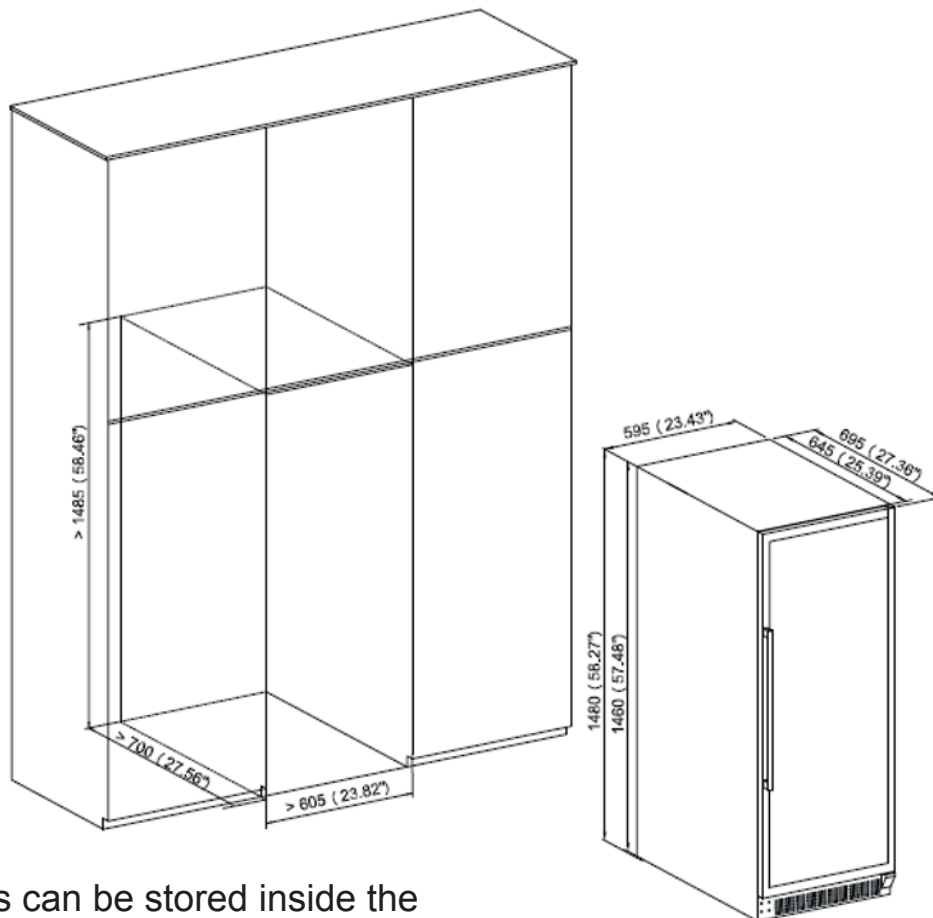

Wine bottles can be stored inside the appliance 1 hour after turning on, when you feel it is cool inside the appliance.

Description of the appliance

Overall image

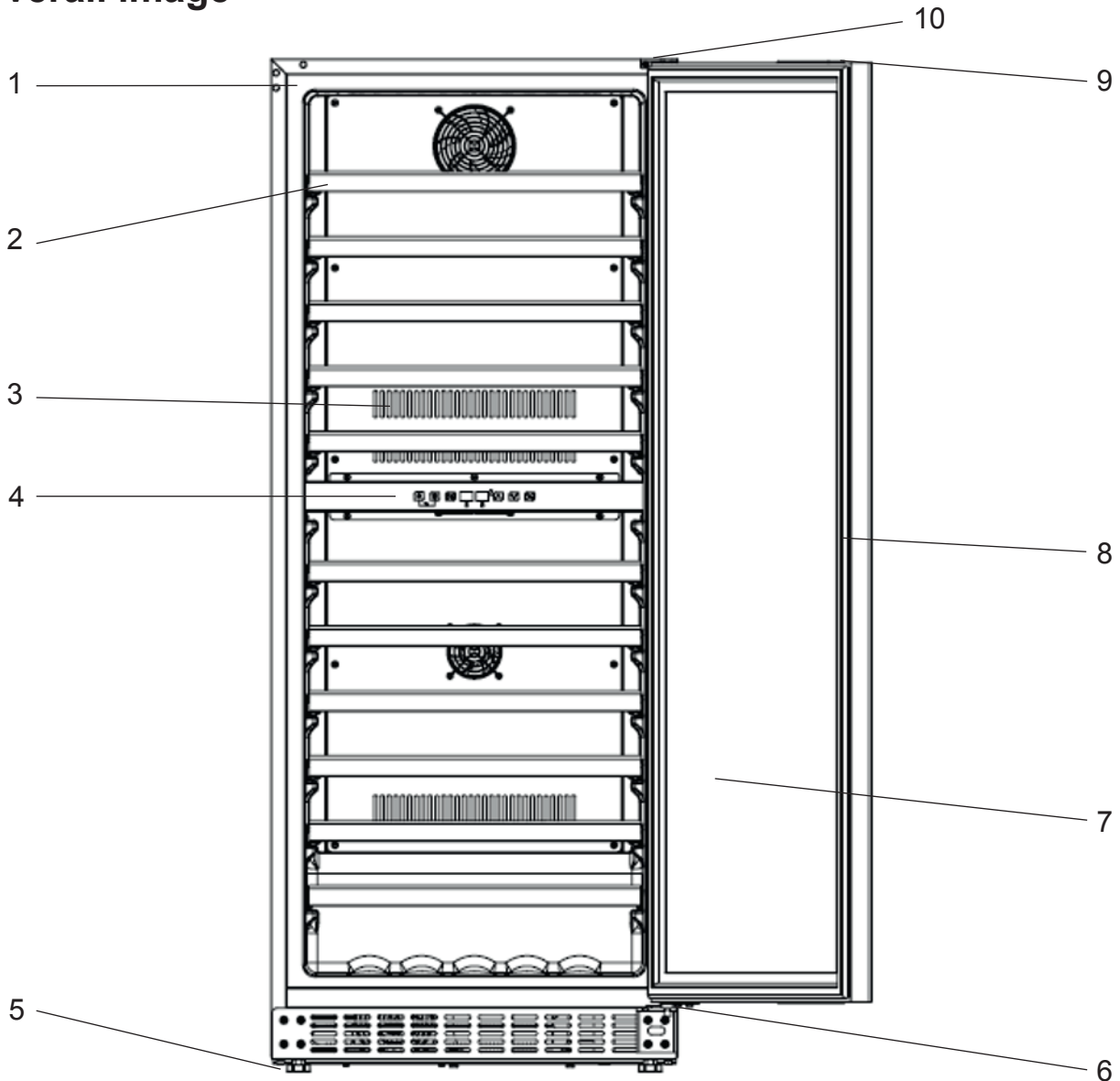

- | | |
|--------------------|-----------------|
| 1. Housing | 6. Lower hinge |
| 2. Shelf | 7. Door |
| 3. Cover board | 8. Door seal |
| 4. Control panel | 9. Handle |
| 5. Adjustable foot | 10. Upper Hinge |

Note:

Shelves, door frame, handle and other accessories may be different according to different models and configuration.

All photos in this manual are for reference. The appliance you buy might not be exactly the same as shown here.

Please refer to the actual product.

Reversing the door

Note: Two people are required to complete the door change.

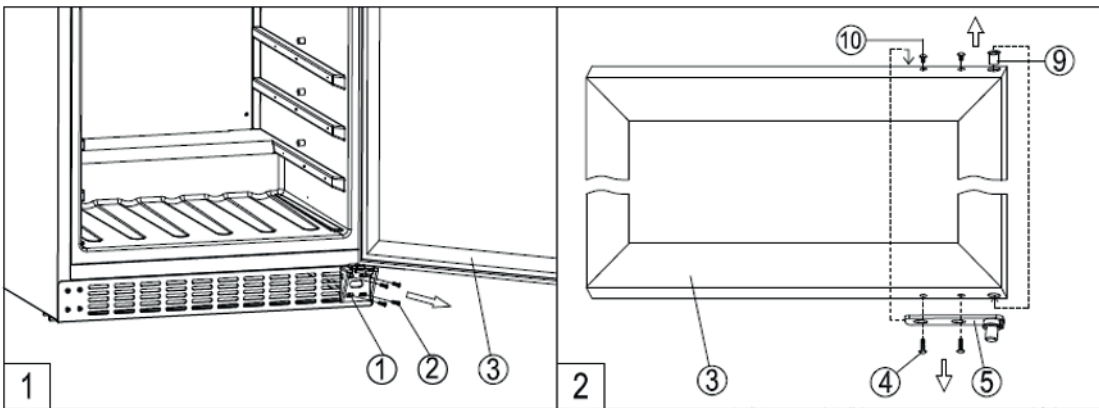

1. Hold the door (3), unscrew the four screws (2) from the lower hinge (1), and remove the lower hinge (1). Slowly take out the door (3) from the top right hinge (7) from top to bottom. [Figure 1].
2. Unscrew the two screws (4) used to fix the lower hinge plate (5) at the bottom right corner of the door (3). Take out the door shaft sleeve (9) and two decorative screws (10) on the top right corner, and install them in the corresponding position on the lower right corner. Then use two screws (4) to install the lower hinge plate (5) at the corresponding position on the top right corner [Figure 2].

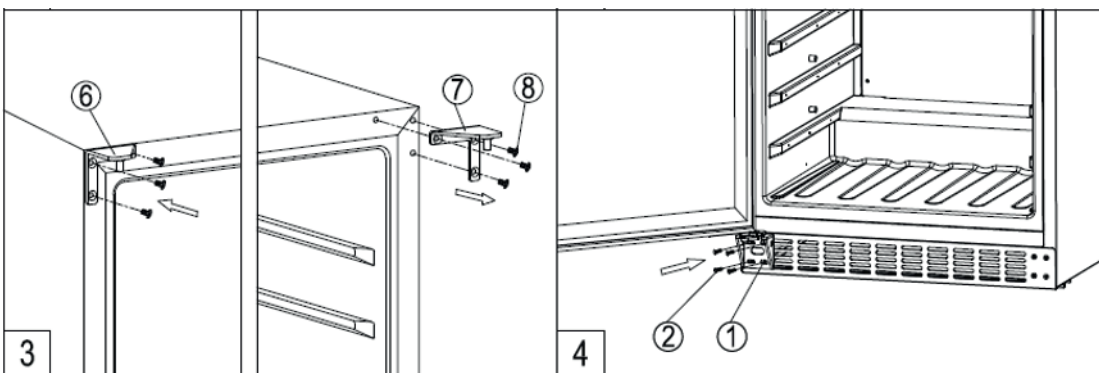

3. Unscrew the three screws (8) and remove the top right hinge (7). Install the top left hinge (6) at the corresponding position in the top left corner of the cabinet [Figure 3].
4. Slowly insert the door (3) onto the shaft of the top left hinge (6), and then insert the lower hinge (1) onto the shaft of the lower hinge plate (5). Use four screws (2) to fix the lower hinge (1) at the corresponding position in the lower left corner of the cabinet [Figure 4].

Operation

Start operation

1. Cleaning the compartment

Before powering on, clean inside of the appliance and check the drainage pipe is connected. (For details, please refer to the “Maintenance and cleaning”).

2. Stabilising the appliance

Before powering on, level the appliance on a firm & dry floor for at least 30 minutes.

3. Power on

Once the appliance has started operation, it will cool down internally after 1 hour, otherwise you should check the power connection.

Control panel

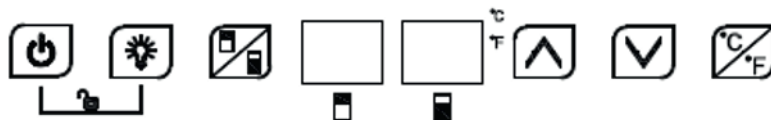

All keys will be invalid in lock mode. Please unlock first.



ON/OFF

1. Hold down this key for 3 seconds to power down, the unit will go into stand-by mode.
2. Hold down this key again for 3 seconds to return back to normal operation.



Light

Press this key to turn on or turn off the LED lights inside. In stand-by mode, this key is invalid.



Zone switch

Press this key to switch between upper zone and lower zone for choosing which zone to set temperature. Press the key once, the LED display in chosen zone will flash regularly. Press up and down key to set temperature. Press the key again to switch which zone to set temperature.



UP

Press the key once, the LED Display will flash showing current set temperature. Continue pressing to adjust set temperature, one press increases temperature by 1°C. Flashing will stop after 5 seconds without any input and new set temperature will be saved. LED display will return to show actual temperature inside.



Down

Press this key once, LED Display will flash showing current set temperature. Continue pressing to adjust set temperature, one press reduces temperature by 1°C. Flashing will stop after 5 seconds with no input and new set temperature will be saved. LED display will return to show actual temperature inside.



Child Lock

1. Lock: Press both these keys at the same time for 3 seconds to lock.
2. Unlock: Press both these keys at the same time for 3 seconds to unlock.



Fahrenheit/Celsius display interchange

Switch temperature display between Fahrenheit and Celsius by pressing and holding this key for 3 seconds.



Attention

1. The default temperature of this product is 12°C, and the corresponding temperature range needs to be set according to the actual wine stored.
2. For both upper and lower zone, the cooling temperature can be set from **5 to 22°C**. The temperature of the lower zone can only be set equal to or higher than that of the upper zone.

Wine storage

- The appliance is equipped with sufficient shelves to allow your collection of wine to mature quietly and peacefully.
- Full wood shelves loading capacity: **122** bottles. (Standard Bordeaux with 750ml).

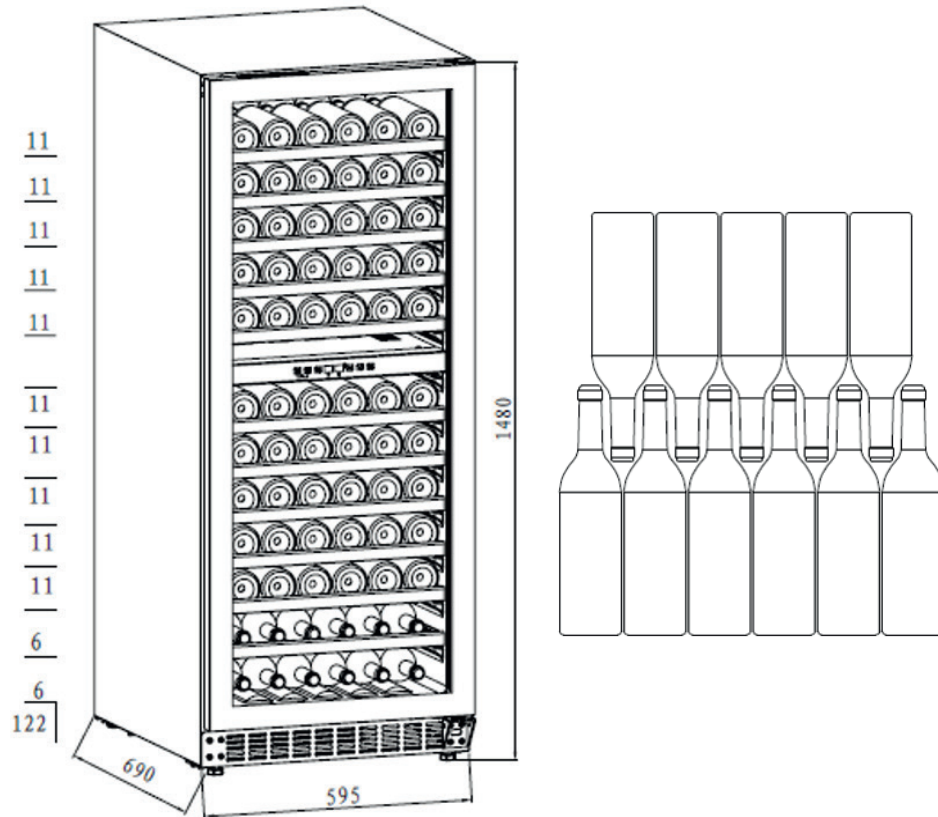

- Loading capacity will vary depending on bottle arrangement or different bottle sizes.
- Each shelf is designed to support 1 or 2 layers of wine bottles. More than 2 layers of bottles on one shelf is not recommended.
- Each shelf sliding roller can be pulled out partly to store wine bottles easily.
- Ensure the door is opened wide enough before pulling out shelves.
- Avoid putting wine bottles directly in front of the fan to allow proper cooling circulation and improve cooling efficiency. If the wine chiller will not be used for an extended period, it is recommended to power it off, clean it carefully, and open the door for ventilation.
- The below table is the recommended temperature for wine storing & drinking:

Red Wine	15 - 18°C
White Wine	9 - 14°C
Rose Wine	10 - 11°C
Champagne & Sparkling Wine	5 - 8°C

Troubleshooting

The appliance makes lots of noise?	<ul style="list-style-type: none"> • Adjust the front foot, keep the appliance level. • Keep the appliance spaced away from walls.
There is a liquid flowing sound inside the cabinet?	<ul style="list-style-type: none"> • It is normal because of the refrigerant working inside.
The appliance does not start?	<ul style="list-style-type: none"> • Make sure the appliance is connected to the power source properly. • Make sure to switch on the power. • The compressor re-starts after 5 minutes following a power cut.
The compressor runs continuously?	<ul style="list-style-type: none"> • If no cold is being produced, call the retailer's after-sale service.
The door does not seal tightly?	<ul style="list-style-type: none"> • After a long life of use, the door seal may become stiff & distorted partially. <ol style="list-style-type: none"> 1. Heat the door seal with a hair dryer or hot towel. 2. The door seal will be softened to allow a better seal
The appliance does not cool sufficiently?	<ul style="list-style-type: none"> • Adjust temperature setting. • Keep the appliance away from sunlight or heat. • Please do not open the door frequently.
There are unpleasant smells inside the cabinet?	<ul style="list-style-type: none"> • A little bit of plastic smell for newly-bought appliance is normal and will disappear after a short time. • Clean the compartment and ventilate it for a few hours.
There is condensation on the glass door?	<ul style="list-style-type: none"> • Do not open the door frequently or leave open for a long time. • Do not set the temperature too low. • High ambient temperature and humidity can cause condensation.
The light is not working?	<ul style="list-style-type: none"> • Check the power supply first. • Call the retailer's after-sale service if the light is broken.
Why is the alarm sounding?	<ul style="list-style-type: none"> • When a system malfunction occurs and the alarm sounds, press any key on the control panel to cancel the alarm sound.
What do the different error codes mean?	<ul style="list-style-type: none"> • Error code: When the temperature sensor of the upper zone failure occurs, error code displays: "E1" for open circuit; "E2" for short circuit. When the defrost sensor failure occurs, error code displays: "E3" for open circuit; "E4" for short circuit. When the temperature sensor of Lower zone failure occurs, error code displays: "E5" for open circuit; "E6" for short circuit.

Maintenance and cleaning

Cleaning

- Disconnect the appliance before cleaning.
- Clean the appliance with a soft cloth or sponge with water.
- Do not use organic solvents, alkaline detergent, boiling water, washing powder or acidic liquid etc.
- Do not flush the compartment of the appliance.
- Clean regularly surfaces that can come in contact with accessible drainage systems.

The below items will damage the surface of the wine chiller:



Alkaline detergent



Organic solvents

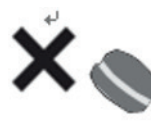

Brushes



Boiling water

Power cut

Most power cuts can be resolved within a short time. To protect your wines during a power cut, avoid opening the door as much as possible. During very long power cuts, take the necessary measures to protect your wine.

Powered off for an extended period

Remove all bottles from the appliance, switch off, defrost, clean, dry, and leave the door open to prevent mould developing within the appliance.

 If the appliance is disconnected or if there is a power cut, you must wait at least five minutes before re-starting.

Moving the appliance

- Turn off the power supply and unplug the appliance.
- Remove all bottles from the appliance.
- When moving the appliance, do not lean the appliance over 45°.



Technical parameters

Product model	EWC122IB
Voltage/frequency	220-240V~/50Hz
Refrigerant/amount	R600a/42g
Effective volume	320L
Loading capacity	122 bottles
Net weight	81.8kg
Unit dimension (WxDxH)	595×690×1480 mm
Packing dimension (WxDxH)	660×755×1535 mm

Remarks:

1. The net weight includes shelves, and the unit dimension is without handle on the door.
2. The manufacturer reserves all rights to change the above parameters without prior notice. Please refer to the nameplate of your appliance.
3. Loading capacity will vary in terms of different bottle arrangement or different bottle sizes (standard Bordeaux with 750ml is applied here).

Manufacturer Guarantee

This warranty is provided in Australia by Glen Dimplex Australia Pty Limited ABN 69 118 275 460 (**Phone number 1300 556 816**) and in New Zealand by Glen Dimplex New Zealand Limited NZBN 9429000069823 (**Phone number 09 274 8265**) in respect of the **Euromaid** product.

1. Euromaid Express Warranty

Subject to the exclusions below, we warrant that the product will not have any electrical or mechanical breakdowns within:

- a) In the case of **Euromaid** products used for personal, domestic or household purposes, a period of **2 years** from the date the product is purchased as a brand-new product from a retailer located in Australia / New Zealand.
- b) In the case of **Euromaid** products used for purposes other than personal, domestic or household purposes (including business or commercial use), a period of 90 days from the date the product is purchased as a brand-new product from a retailer located in Australia / New Zealand. **Euromaid** products are designed and intended for domestic use only; and
- c) All warranty repairs must be carried out by Glen Dimplex or their nominated service agent.

Note: warranty periods detailed above may vary in line with agreements with select retail and builder partners and may differ between Australia and New Zealand.

The benefits conferred by this express warranty are in addition to the Consumer Guarantees referred to in section 3 and any other statutory rights you may have under the Australian / New Zealand Consumer Law and/or other applicable laws.

2. Warranty exclusions

This express warranty does not apply where:

- a) The product has been installed, used or operated otherwise than in accordance with the product manual or other similar documentation provided to you with the product;
- b) The product requires repairs due to damage resulting from accident, misuse, incorrect installation, insect or vermin infestation, improper liquid spillage, cleaning or maintenance, unauthorised modification, use on an incorrect voltage, power surges and dips, voltage supply problems, tampering or unauthorised repairs by any persons, use of defective or incompatible accessories or exposure to abnormally corrosive conditions, events independent of human control which occurred after the goods left the control of Glen Dimplex;
- c) The repair relates to the replacement of consumable parts such as fuses and bulbs or any other parts of the product which require routine replacement;
- d) You are unable to provide us with reasonable proof of purchase for the product;

- e) the breakdown occurs after the expiry of the express warranty period set out in section 1 or
- f) the product was not purchased in Australia / New Zealand as a brand-new product.

3. Consumer guarantees

Our goods come with guarantees that cannot be excluded under the Australian / New Zealand Consumer Law. You are entitled to a replacement or refund for a major failure and for compensation for any other reasonably foreseeable loss or damage. You are also entitled to have the goods repaired or replaced if the goods fail to be of acceptable quality and the failure does not amount to a major failure.

4. How to make a claim

You may make a claim under this warranty through our website, contacting our customer care line or via email. Contact details for Glen Dimplex Australia and New Zealand can be found at the end of this document.

To make a valid claim under this warranty, you must:

- a) Lodge the claim with us as soon as possible and no later than 14 days after you first become aware of the breakdown;
- b) Provide us with the product serial number;
- c) Provide us with reasonable proof of purchase for the product. This can take the form of a store receipt, new home handover form or other payment receipt documentation; and
- d) If required by us, provide us (or any person nominated by us) with access to the premises at which the product is located at times nominated by us (so that we can inspect the product).

5. Warranty claims

If you make a valid claim under this warranty and none of the exclusions set out in section 2 apply, we will, at our election, either repair the product or replace the product with a product of identical specification (or where the product is superseded or no longer in stock, with a product of as close a specification as possible).

Goods presented for repair may be replaced by refurbished goods of the same type rather than being repaired. Refurbished parts may be used to repair the goods.

Products are designed and supplied for normal domestic use. We will not be liable to you under this warranty for business loss or damage of any kind whatsoever.

Glen Dimplex Australia Pty Ltd

www.glendimplex.com.au

Australia

Ph: 1300 556 816

customer.care.ha@glendimplex.com.au

Glen Dimplex New Zealand Ltd

www.glendimplex.co.nz

New Zealand

Ph: 09 274 8265

nztechserv@glendimplex.co.nz

READ THE INSTRUCTION BOOKLET BEFORE INSTALLING AND USING THE APPLIANCE.

The manufacturer will not be responsible for any damage to property or to persons caused by incorrect installation or improper use of the appliance.

The manufacturer is not responsible for any inaccuracies, due to printing or transcription errors, contained in this manual. In addition, the appearance of the figures reported is also purely indicative.

The manufacturer reserves the right to make changes to its products when considered necessary and useful, without affecting the essential safety and operating characteristics.

Glen Dimplex constantly seeks ways to improve the specifications and designs of their products. Whilst every effort is made to produce up to date literature, this document should not be regarded as an infallible guide. Actual product only should be used to derive cut out sizes.

All appliances must be installed by a qualified person/s with adherence to the relevant electrical, plumbing and building codes, with compliance being issued as required by state or national legislation.

Additionally, all upright cookers must have the anti-tilt device installed correctly in adherence to the relevant standards by a licenced installer.

For maximum effectiveness and efficiency all rangehoods should be installed with the use of ductwork, by a licenced installer with adherence to the relevant state and national building codes and regulations.

All Glen Dimplex appliances are for Domestic use only, and must be installed by a licence installer into Domestic Applications only, without exception and to the required Authorities guidelines. Any installation outside of this will VOID warranty. Alfresco areas are not a Domestic application.

Euromaid

Distributed by:

Glen Dimplex Australia Pty Ltd

www.glendimplex.com.au

Glen Dimplex New Zealand Ltd

www.glendimplex.co.nz

For service advice, please contact the Customer Care Centre by phone or email below.

Australia

Ph: 1300 556 816

customer.care.ha@glendimplex.com.au

New Zealand

Ph: 09 274 8265

nztechserv@glendimplex.co.nz