

# Euromaid

**installation & operating  
instructions and cooking  
guidance**

**Double Oven**

Model CDDW 60  
CDDB 60  
CDDS 60

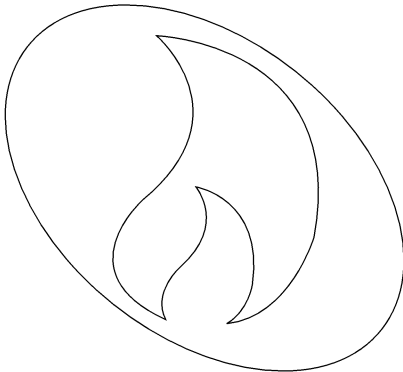

get the **best** from your new cooker



## **Please read this manual first.**

Dear Customer,

We would like you to obtain best performance with your product that has been manufactured in modern facilities and passed through strict quality control procedures.

Therefore, we advise you to read through this User Manual carefully before using your product and keep it for future reference. If you hand over the product to someone else, deliver the User Manual as well.

## **The User Manual will help you use the product in a fast and safe way.**

- Read the User Manual before installing and operating the product.
- You must strictly observe the safety instructions.
- Keep this User Manual within easy reach for future reference.
- Also read other documents supplied with the product.

Remember that this User Manual may also be applicable for several other models.

Differences between models are explicitly identified in the manual.

## **Explanation of symbols**

Throughout this User Manual the following symbols are used:

 Important information or useful hints about usage.

 Warning for hazardous situations with regard to life and property.

 Warning for electric shock.

 Warning for risk of fire.

 Warning for hot surfaces.

# Table of Contents

---

## **1 General information 4**

Overview ..... 4

Technical specifications ..... 5

Accessories supplied with the unit ..... 6

## **2 Safety instructions 8**

General safety ..... 8

Safety when working with electricity ..... 9

Intended use ..... 9

Safety for children ..... 9

## **3 Installation 11**

Before installation ..... 11

Installation and connection ..... 12

Disposal ..... 14

Disposing of packaging material ..... 14

Disposing of the old product ..... 14

Future Transportation ..... 14

## **4 Preparation 15**

Tips for saving energy ..... 15

Initial use ..... 15

Initial time setting ..... 15

First cleaning of the appliance ..... 16

Initial heating ..... 16

## **5 How to use the hob 17**

General information about cooking .... 17

Using the hobs ..... 18

## **6 How to operate the oven 19**

General information on baking, roasting  
and grilling ..... 19

How to operate the electric oven ..... 19

Operating modes ..... 20

Using the oven clock ..... 20

How to use the program lock ..... 22

Using the clock as an alarm ..... 22

Cooking times table ..... 23

How to operate the top oven part ..... 25

Cooking times table ..... 25

How to operate the grill -Top oven .... 26

Electric grilling guide ..... 26

## **7 Maintenance and care 28**

General information ..... 28

Cleaning the hob ..... 28

Cleaning the control panel ..... 29

Cleaning the oven ..... 29

Removal of oven door ..... 29

Removing the door inner glass ..... 30

Replacing the oven lamp ..... 31

## **8 Troubleshooting 32**

# 1 General information

## Overview

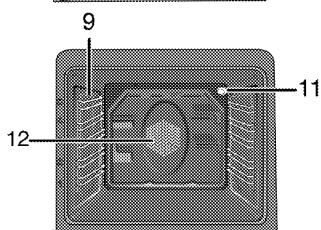
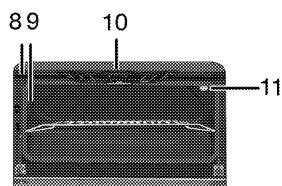
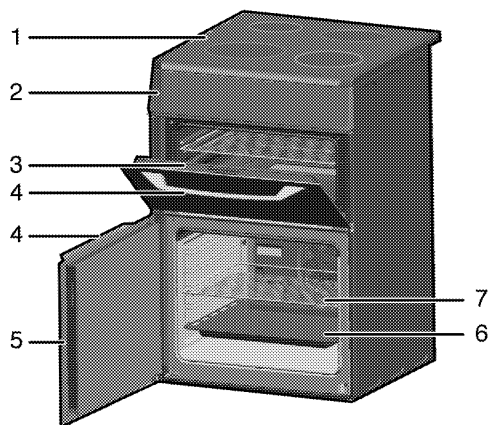

- |   |                |    |                                |
|---|----------------|----|--------------------------------|
| 1 | Burner plate   | 7  | Wire shelf                     |
| 2 | Control panel  | 8  | Door switch                    |
| 3 | Top oven door  | 9  | Shelf positions                |
| 4 | Handle         | 10 | Grill heating element          |
| 5 | Main oven door | 11 | Lamp                           |
| 6 | Tray           | 12 | Fan motor (behind steel plate) |

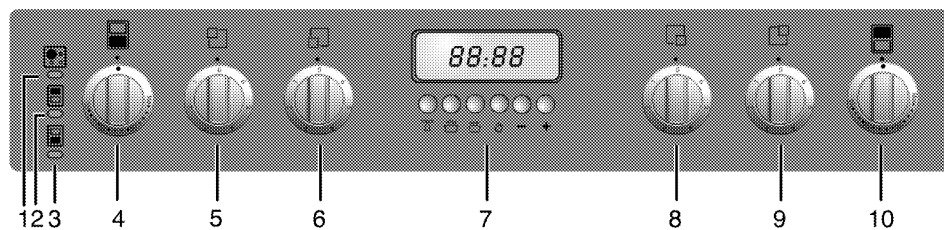

- |   |   |    |  |
|---|---|----|--|
| 1 | Warning lamp                            | 8  | Single-circuit cooking plate Front right |
| 2 | Thermostat lamp for top oven            | 9  | Single-circuit cooking plate Rear right  |
| 3 | Thermostat lamp for main oven           | 10 | Top oven function knob                   |
| 4 | Main oven function knob                 |    |  |
| 5 | Single-circuit cooking plate Rear left  |    |  |
| 6 | Single-circuit cooking plate Front left |    |  |
| 7 | Digital timer                           |    |  |

## Technical specifications

<b>GENERAL</b>	
External dimensions (height / width / depth)	900 mm/600 mm/600 mm
Voltage / frequency	220-240 V ~ 50 Hz
Total power consumption	10 kW
Fuse	min. 32 A
Cable type / section	H05VV-FG 3 x 2,5 mm <sup>2</sup> / 5 x 1,5 mm <sup>2</sup>
Cable length	max. 2 m
<b>HOB</b>	
<b>Burners</b>	
Rear left	<b>Single-circuit cooking plate</b>
Dimension	140 mm
Power	1200 W
Front left	<b>Single-circuit cooking plate</b>
Dimension	180 mm
Power	1700 W
Front right	<b>Single-circuit cooking plate</b>
Dimension	140 mm
Power	1200 W
Rear right	<b>Single-circuit cooking plate</b>
Dimension	180 mm
Power	1700 W
<b>OVEN/GRILL</b>	
Top oven	<b>Conventional oven</b>
Energy efficiency class <sup>#</sup>	A
Inner lamp	15-25 W
Grill power consumption	2.2 kW
Main oven	<b>Fan oven</b>
Energy efficiency class <sup>#</sup>	A
Inner lamp	15-25 W

<sup>#</sup> Basics: Information on the energy label of electrical ovens is given in accordance with the EN 50304 standard. Those values are determined under standard load with bottom-top heater or fan assisted heating (if any) functions.

Energy efficiency class is determined in accordance with the following prioritization depending on whether the relevant functions exist on the product or not. 1-Cooking with eco-fan, 2- Turbo slow cooking, 3- Turbo cooking, 4- Fan assisted bottom/top heating, 5-Top and bottom heating.



### Important

Technical specifications may be changed without prior notice to improve the quality of the product.



### Important

Figures in this manual are schematic and may not exactly match your product.



### Important

Values stated on the product labels or in the documentation accompanying it are obtained in laboratory conditions in accordance with relevant standards. Depending on operational and environmental conditions of the product, these values may vary.

## Accessories supplied with the unit



### Important

Accessories supplied can vary depending on the product model. All the accessories described in the user manual may not exist on your product.

#### Baking tray

Can be used for pastries, frozen foods and big roasts.

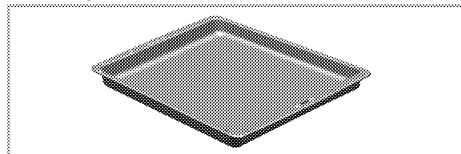

#### Deep roasting tray

Can be used for pastries, big roasts, foods with liquid content and during grilling as dripping pan.

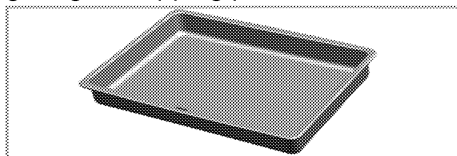

#### Pastry tray

It is recommended for pastries such as cookies and biscuits.

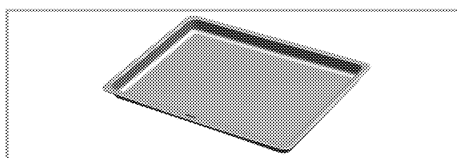

#### Small baking tray

Can be used for small portions. This baking tray is placed onto the wire shelf.

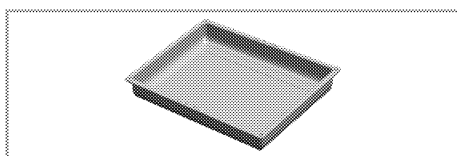

#### Wire shelf

Can be used for roasting and as deposit for baking, roasting and casserole dishes.

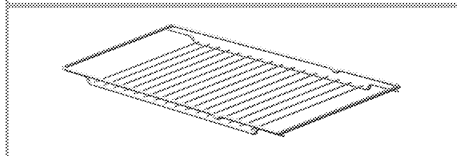
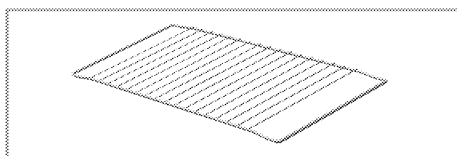

### **Small wire shelf (for use with supplied tray)**

Can be used for grilling and fat collection within tray to prevent the oven from getting dirty.

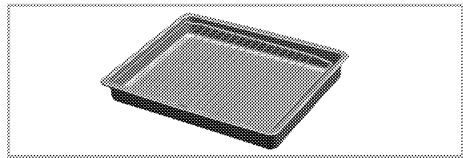

### **Proper positioning of the wire shelf and tray on sliding shelves**

Trays and wire shelves used with the sliding shelf (model dependant) must be positioned correctly with the inner edges of the shelf placed over the pins on the sliding shelf. This holds the shelf firmly in place".

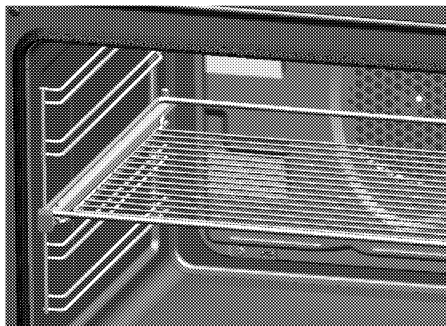
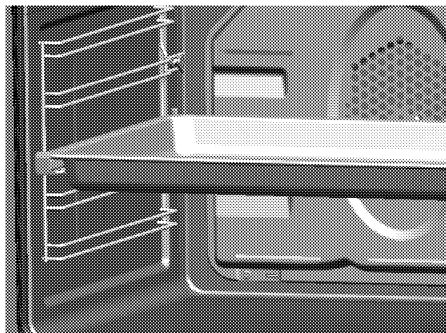



## 2 Safety instructions

---

### General safety

- This product is not intended to be used by persons with physical, sensory or mental disorders or unlearned or inexperienced people (including children) unless they are attended by a person who will be responsible for their safety or who will instruct them accordingly for use of the product.  
Children must be supervised to prevent them from tampering with the product.
- Connect the product to an earthed outlet/line protected by a fuse of suitable capacity as stated in the "Technical specifications" table. Have the earthing installation made by a qualified electrician while using the product with or without a transformer. Our company shall not be liable for any problems arising due to the product not being earthed in accordance with the local regulations.
- If the supply cord is damaged, it must be replaced by the manufacturer, its service agent or similar qualified persons in order to avoid a hazard.
- Do not operate the product if it is defective or has any visible damage.
- Do not carry out any repairs or modifications on the product. However, you may remedy some troubles that do not require any repairs or modifications. See *Troubleshooting, page 32*.
- Never wash down the product with water! There is the risk of electric shock!
- Never use the product when your judgment or coordination is impaired by the use of alcohol and/or drugs.
- Product must be disconnected from the mains during installation, maintenance, cleaning and repair procedures.
- Be careful when using alcoholic drinks in your dishes. Alcohol evaporates at high temperatures and may cause fire since it can ignite when it comes into contact with hot surfaces.
- Do not heat closed tins and glass jars in the oven. The pressure that would build-up in the tin/jar may cause it to burst.
- Do not place any flammable materials close to the product as the sides may become hot during use.
- Do not place baking trays, dishes or aluminium foil directly onto the bottom of the oven. The heat accumulation might damage the bottom of the oven.
- Keep all ventilation slots clear of obstructions.
- Product may be hot when it is in use. Never touch the hot burners, inner sections of the oven, heaters and etc.

- Always use heat resistant oven gloves when putting in or removing dishes into/from the hot oven.
- Do not use the product with front door glass removed or cracked.
- Rear surface of the oven gets hot when it is in use. Make sure that the gas/electrical connection does not contact the rear surface; otherwise, connections can get damaged.
- Do not trap the mains cable between the oven door and frame and do not route it over hot surfaces. Otherwise, cable insulation may melt and cause fire as a result of short circuit.
- Make sure that the product function knobs are switched off after every use.
- Vapour pressure that build up due to the moisture on the hob surface or at the bottom of the pot can cause the pot to move. Therefore, make sure that the oven surface and bottom of the pots are always dry.

	<p><b>Important</b></p> <p><b>The appliance is not intended to be operated by means of an external timer or separate remote control.</b></p>
---	--

## Safety when working with electricity

Defective electric equipment is one of the major causes of house fires.

- Any work on electrical equipment and systems should only be carried out by authorized and qualified persons.

- In case of any damage, switch off the product and disconnect it from the mains. To do this, turn off the fuse at home.
- Make sure that fuse rating is compatible with the product.

## Intended use

This product is designed for domestic use. Commercial use will void the guarantee.

"CAUTION: This appliance is for cooking purposes only. It must not be used for other purposes, for example room heating."

This product should not be used for warming the plates under the grill, drying towels, dish cloths etc. by hanging them on the oven door handles. This product should also not be used for room heating purposes. The manufacturer shall not be liable for any damage caused by improper use or handling errors.

The oven can be used for defrosting, baking, roasting and grilling food.

## Safety for children

- Electrical and/or gas products are dangerous to children. Keep children away from the product when it is operating and do not allow them to play with the product.
- Accessible parts of the appliance will become hot whilst the appliance is in use. Children should be kept away until the product has cooled down.
- "**CAUTION:** Accessible parts may be hot when the grill is in use."

Young children should be kept away."

- Do not place any items above the appliance that children may reach for.
- When the door is open, do **not** load any heavy object on it and do **not** allow children to sit on it. It

may overturn or door hinges may get damaged.

- The packaging materials will be dangerous for children. Keep the packaging materials away from children. Please dispose of all parts of the packaging according to environmental standards.

**SAVE THESE INSTRUCTIONS**

## 3 Installation

### Before installation

To ensure that critical air gaps are maintained under the appliance, we recommend that this appliance is mounted on a solid base and that the feet do not sink into any carpet or soft flooring.

The kitchen floor must be able to carry the weight of the appliance plus the additional weight of cookware and bakeware and food.

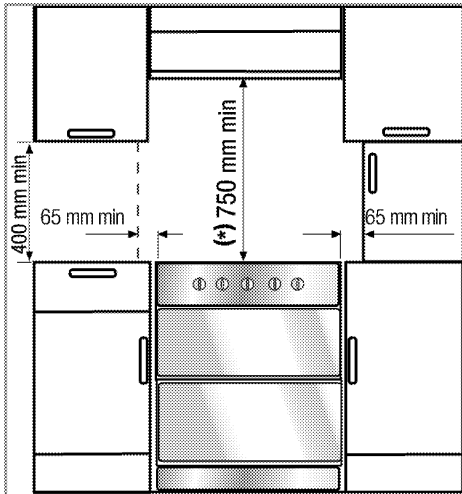

A safety distance must be left between the appliance and the kitchen walls and furniture. See figure (values in mm).

- It can be used with cabinets on either side but in order to have a minimum distance of 400 mm above hotplate level allow a side clearance of 65 mm between the appliance and any wall, partition or tall cupboard.
- It can also be used in a free standing position. Allow a

minimum distance of 750 mm above the hob surface.

- (\*) If a cooker hood is to be installed above the cooker, refer to cooker hood manufacturer's instructions regarding installation height (min 650mm).
- Movement of your appliance is most easily achieved by lifting the front as follows and pulling towards. Open the top oven door and the bottom oven door sufficiently to allow a comfortable grip on the underside front edge of the oven roofs. While gripping, it should be avoided to damage any grill elements or oven interior furniture.
- The appliance corresponds to device class 1, i.e. it may be placed with the rear and **one** side to kitchen walls, kitchen furniture or equipment of any size. The kitchen furniture or equipment on the **other** side may only be of the same size or smaller.
- Any kitchen furniture next to the appliance must be heat-resistant (100 °C min.).



### Important

The appliance must be secured against overbalancing by using the supplied chain on your oven. Fasten hook (1) to the kitchen wall (5) and connect safety chain (2) to the hook.

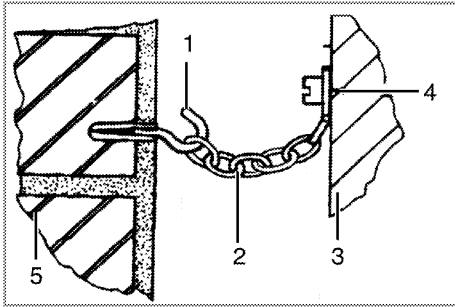

- 1 Hook (is not supplied)
- 2 Safety chain (supplied and mounted to oven)
- 3 Rear of cooker
- 4 Firmly fix chain to cooker rear
- 5 Kitchen wall

## Installation and connection

Product can only be installed and connected in accordance with the statutory installation rules.

**i Important**  
Do not install the appliance next to refrigerators or freezers. The heat emitted by the appliance will lead to an increased energy consumption of cooling appliances.

- Carry the product with at least two persons.
- Product must be placed directly on the floor. It must not be placed onto a base or a pedestal.

**i NOTICE**  
Material damage!  
The door and/or handle must not be used for lifting or moving the appliance.

## Electrical connection

Connect the product to a grounded outlet/line protected by a fuse of suitable capacity as stated in the "Technical specifications" table. Have the grounding installation made by a qualified electrician while using the product with or without a transformer. Our company shall not be liable for any damages that will arise due to using the product without a grounding installation in accordance with the local regulations.

**⚠ DANGER**  
**Risk of electric shock, short circuit or fire by unprofessional installation!**  
The appliance may be connected to the mains supply only by an authorized qualified person and the appliance is only guaranteed after correct installation.

**⚠ DANGER**  
**Risk of electric shock, short circuit or fire by damage of the mains lead!**  
The mains lead must not be clamped, bent or trapped or come into contact with hot parts of the appliance.  
If the mains lead is damaged, it must be replaced by a qualified electrician.

The mains supply data must correspond to the data specified on the type label of the product. The rating plate is either seen when the door or the lower cover is opened or it is located at the rear wall of the unit depending on the unit type.

Power cable of your product must comply with the values in "Technical specifications" table.

**⚠ DANGER**  
**Risk of electric shock!**  
 Before starting any work on the electrical installation, please disconnect the appliance from the mains supply.

**Connecting the power cable**

1. **If a power cable is not supplied together with your product,** a power cable that you would select from the table (*Technical specifications, page 5*) in accordance with the electrical installation at your home must be connected to your product by following the instructions in cable diagram.

If it is not possible to disconnect all poles in the supply power, a disconnection unit with at least 3 mm contact clearance (fuses, line safety switches, contactors) must be connected and all the poles of this disconnection unit must be adjacent to (not above) the product in accordance with IEE directives. Failure to obey this instruction may cause operational problems and invalidate the product warranty.

**i NOTICE**  
 Additional protection by a residual current circuit breaker is recommended.

2. Open the terminal block cover with a screwdriver.
3. Insert the power cable through the cable clamp below the terminal and

secure it to the main body with the integrated screw on cable clamping component.

4. Connect the cables according to the supplied diagram.

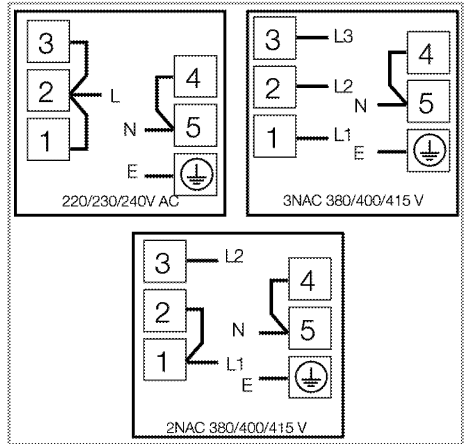

5. After completing the wire connections, close the terminal block cover.
6. Route the power cable so that it will not contact the product and get squeezed between the product and the wall.

**i NOTICE**  
 Power cable must not be longer than 2 m because of safety reasons.

- Push the product towards the kitchen wall.
- Hook safety chain.
- **Adjusting the feet of oven**  
 Vibrations during use may cause cooking vessels to move. This dangerous situation can be avoided if the product is level and balanced.  
 For your own safety please ensure the product is level by adjusting the four feet at the bottom by

turning left or right and align level with the work top.

### Final check

1. Reconnect the product to the mains.
2. Open gas supply.

## Disposal

### Disposing of packaging material

Packaging materials are dangerous to children. Keep packaging materials in a safe place out of reach of children. Packaging materials of the product are manufactured from recyclable materials. Dispose of them properly and sort in accordance with recycled waste instructions. Do not dispose of them with normal domestic waste.

### Disposing of the old product





Dispose of the old product in an environmentally friendly manner. This equipment bears the selective sorting symbol for waste electrical and electronic equipment (WEEE). This means that this equipment must be handled pursuant to European Directive 2002/96/EC in order to be recycled or dismantled to minimize its impact on the environment. For further information, please contact local or regional authorities.

Refer to your local dealer or solid waste collection centre in your area to learn how to dispose of your product. Before disposing of the product, cut off the power cable plug and make the door lock (if any) unusable to avoid dangerous conditions to children.

## Future Transportation

- Keep the product's original carton and transport the product in it. Follow the instructions on the carton. If you do not have the original carton, pack the product in bubble wrap or thick cardboard and tape it securely.
- To prevent the wire grill and tray inside the oven from damaging the oven door, place a strip of cardboard onto the inside of the oven door that lines up with the position of the trays. Tape the oven door to the side walls.
- Do not use the door or handle to lift or move the product.

	<b>NOTICE</b> Do not place other items on the top of the appliance. The appliance must be transported upright.
	<b>Important</b> Check the general appearance of your product for any damages that might have occurred during transportation.

## 4 Preparation

---

### Tips for saving energy

The following information will help you to use your appliance in an ecological way, and to save energy:

- Use dark coloured or enamel coated cookware in the oven since the heat transmission will be better.
- While cooking your dishes, perform a preheating operation if it is advised in the user manual or cooking instructions.
- Do not open the door of the oven frequently during cooking.
- Try to cook more than one dish in the oven at the same time whenever possible. You can cook by placing two cooking vessels onto the wire shelf.
- Cook more than one dish one after another. The oven will already be hot.
- You can save energy by switching off your oven a few minutes before the end of the cooking time. Do not open the oven door.
- Defrost frozen dishes before cooking them.
- Use pots/pans with cover for cooking. If there is no cover, energy consumption may increase 4 times.
- Select the burner which is suitable for the bottom size of the pot to be used. Always select the correct pot size for your dishes. Larger pots require more energy.

- Pay attention to use flat bottom pots when cooking with electric hobs. Pots with thick bottom will provide a better heat conduction. You can obtain energy savings up to 1/3.
- Vessels and pots must be compatible with the cooking zones. Bottom of the vessels or pots must not be smaller than the hotplate.
- Keep the cooking zones and bottom of the pots clean. Dirt will decrease the heat conduction between the cooking zone and bottom of the pot.
- For long cookings, turn off the cooking zone 5 or 10 minutes before the end of cooking time. You can obtain energy savings up to 20% by using the residual heat.

### Initial use

#### Initial time setting



#### Important

Before using the oven the clock time must be set. If the clock time is not set, the main oven will not work.



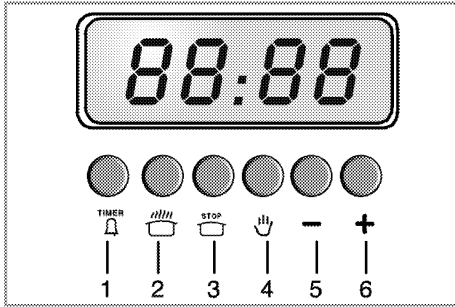

Keys:

- 1 Alarm key
  - 2 Cooking time
  - 3 End of cooking time
  - 4 Unscheduled cooking
- Time adjustment keys:
- 5 Minus key
  - 6 Plus key
1. Keep keys (1) and (2) pressed.
  2. Press (5) or (6) keys to set the time. Press the key with short intervals to increase or reset the time with increments of 1 minute. If you keep the relevant key pressed, the minutes will increase and reset faster.
  3. Release keys (1) and (2).

## First cleaning of the appliance

**i NOTICE**

The surface may get damaged by some detergents or cleaning materials.

Do not use aggressive detergents, cleaning powder/cream or any sharp objects.

1. Remove all packaging materials.
2. Wipe the surfaces of the appliance with a damp cloth or sponge and dry with a cloth.

## Initial heating

Heat up the product for about 30 minutes and then switch it off. Thus, any production residues or layers will be burnt off and removed.

**! WARNING**

**Hot surfaces may cause burns!**

Do not touch the hot surfaces of the appliance. Use oven gloves. Keep children away from the appliance.

## Electric oven

1. Take all baking trays and the wire grill out of the oven.
2. Close the oven door.
3. Select the highest grill power; See *How to operate the electric oven, page 19*.
4. Operate the oven for about 30 minutes.
5. Turn off your oven; See *How to operate the electric oven, page 19*

## Grill oven

1. Take all baking trays and the wire grill out of the oven.
2. Close the oven door.
3. Select the highest oven power for grill oven; see *How to operate the top oven part, page 25*.
4. Operate the grill about 30 minutes.
5. Turn off your grill; see *How to operate the top oven part, page 25*

**i Important**

Smell and smoke may emit during first heating. Ensure that the room is well ventilated.

## 5 How to use the hob

### General information about cooking



#### **DANGER**

#### **Risk of fire by overheated oil!**

When you heat oil, do not leave it unattended.

**Never try to extinguish the fire with water!** When oil has caught fire, immediately cover the pot or pan with a lid. Switch off the hob if safe to do so and phone the fire service.

- Before frying foods, always dry them well and gently place into the hot oil. Ensure complete thawing of frozen foods before frying.
- Do not cover the vessel you use when heating oil.
- Place the pans and saucepans in a manner so that their handles are not over the hob to prevent heating of the handles. Do not place unbalanced and easily tilting vessels on the hob.
- Do not place empty vessels and saucepans on cooking zones that are switched on. They might get damaged.
- Operating a cooking zone without a vessel or saucepan on it will cause damage to the product. Turn off the cooking zones after the cooking is complete.
- As the surface of the product can be hot, do not put plastic and aluminum vessels on it. Clean any melted such materials on the surface immediately.

Such vessels should not be used to keep foods either.

- Use flat bottomed saucepans or vessels only.
- Put appropriate amount of food in saucepans and pans. Thus, you will not have to make any unnecessary cleaning by preventing the dishes from overflowing.

Do not put covers of saucepans or pans on cooking zones.

Place the saucepans in a manner so that they are centered on the cooking zone. When you want to move the saucepan onto another cooking zone, lift and place it onto the cooking zone you want instead of sliding it.

#### **Tips about glass ceramic hobs**

- Glass ceramic surface is heatproof and is not affected by big temperature differences.
- Do not use the glass ceramic surface as a place of storage or as a cutting board.
- Use only the saucepans and pans with machined bottoms. Sharp edges create scratches on the surface.
- Do not use aluminum vessels and saucepans. Aluminum damages the glass ceramic surface.

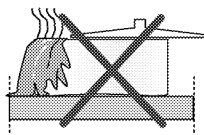

Spills may damage the glass ceramic surface and cause fire.

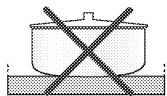

Do not use vessels with concave or convex bottoms.

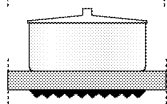

Use only the saucepans and pans with flat bottoms. They ensure easier heat transfer.

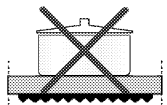

If the diameter of the saucepan is too small, energy will be wasted.



## DANGER

### Broken glass!

Do not let any objects fall onto the hob. Even small objects (e.g. salt shaker) may damage the hob.

Do not use glass ceramic hobs with cracks. Water may enter into the cracks and cause a short circuit.

If the surface is damaged in any way (e. g. visible cracks), switch off the device immediately to reduce the risk of an electric shock.

## Using the hobs

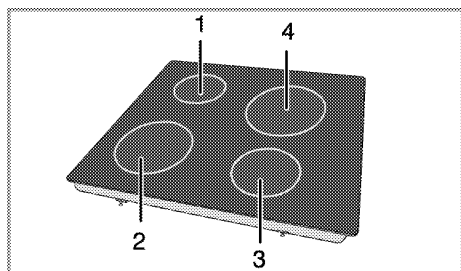

- 1 Single-circuit cooking plate 14-16 cm
  - 2 Single-circuit cooking plate 18-20 cm
  - 3 Single-circuit cooking plate 14-16 cm
  - 4 Single-circuit cooking plate 18-20 cm
- is list of advised diameter of pots to be used on related burners.



## NOTICE

Quick heating glass-ceramic hobs emit a bright light when they are switched on. Do not stare at the bright light.

## Turning on the hotplates

Use hotplate knobs to operate the hotplates. Move the hotplate knobs to the relevant level in order to obtain the desired cooking level.

Cooking level	1	2 – 3	4 – 6
	heating	boiling, resting	cooking, frying

## Turning off the hotplates

Turn the hotplate knob to OFF (upper) position.

## 6 How to operate the oven

### General information on baking, roasting and grilling

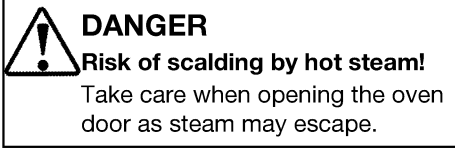

#### Tips for baking

- Use non-stick coated appropriate metal plates or aluminum containers or heat-resistant silicone moulds.
- Make best use of the space on the rack.
- It is recommended to place the baking mould in the middle of the rack.
- Select the correct shelf position before turning the oven or grill on - don't move oven shelves when hot.
- Keep the oven door closed.

#### Tips for roasting

- Seasoning with lemon juice and black pepper will improve the cooking performance when cooking a whole chicken, turkey or a large piece of meat.
- Meat with bones takes about 15 to 30 minutes longer before it is cooked than a roast of the same size without bones.
- You should calculate about 4 to 5 minutes cooking time per centimeter height of the meat.
- Let meat rest in the oven for about 10 minutes after the cooking time. The juice is better distributed all

over the roast and does not run out when the meat is cut.

- Fish in a fire-resistant dish should be placed on the rack at the medium or lower level.

#### Tips for grilling

Grilling is ideal for cooking meat, fish and poultry and will achieve a nice brown surface without it drying out to much. Flat pieces, meat skewers and sausages are particularly suited for grilling as are vegetables with a high water content such as tomatoes and onions.

- Distribute the pieces to be grilled on the wire shelf.
- If the grilling is on the wire shelf, locate a dripping pan under it in order to collect the fat.
- Add some water in the dripping pan for easy cleaning.

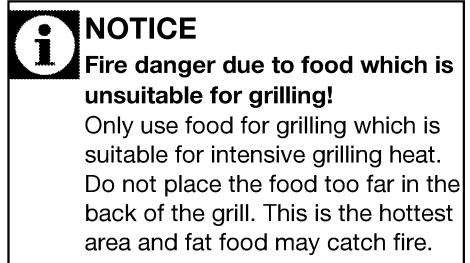

### How to operate the electric oven

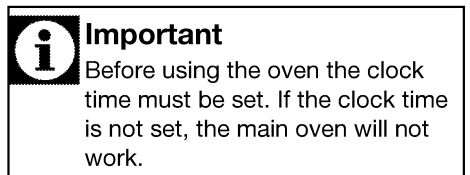

Product is equipped with two ovens. Overview section indicates the relevant knobs for each oven.

## How to operate the main oven

### Select temperature and operating mode

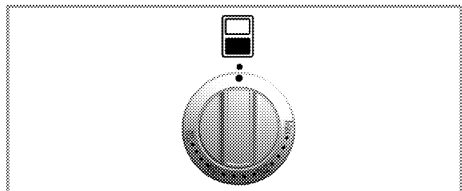

1. Set the Function knob to the desired temperature.  
» Oven heats up to the adjusted temperature and maintains it. During heating, temperature lamp stays on.

### Switching off the electric oven

Turn the Function knob to Off (top) position.

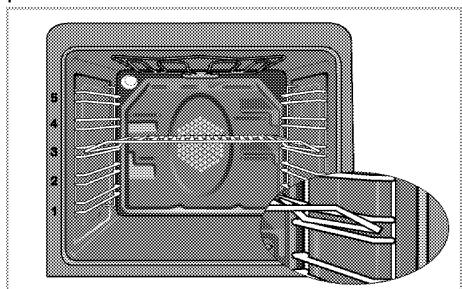

### Rack positions (For models with wire shelf)

It is important to place the wire shelf onto the side rack correctly. Wire shelf must be inserted between the side racks as illustrated in the figure.

Do not let the wire shelf stand against the rear wall of the oven. Slide your wire shelf to the front section of the rack and settle it with the help of the door in order to obtain a good grill performance.

## Operating modes

All functions for the ovens (also included main oven) are listed in this section.

The order of operating modes shown here might deviate from the arrangement on your appliance.

## Using the oven clock

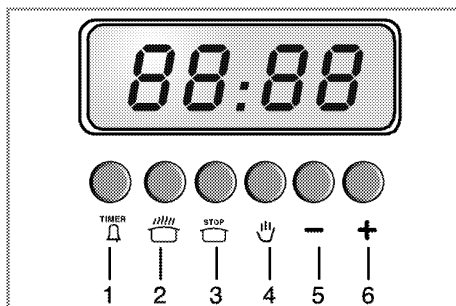

Keys:

- 1 Alarm key
  - 2 Cooking time
  - 3 End of cooking time
  - 4 Unscheduled cooking
- Time adjustment keys:
- 5 Minus key
  - 6 Plus key



### Important

The maximum time to be set for the end of the cooking process is 23 hours and 59 minutes. In case of power cut, program will be canceled. Reprogram is needed.

### Switch on fully automatic operation

In this operation mode you can enter the cooking time after entering the end of cooking time. Oven will calculate the time to start cooking and it will operate automatically at the designated time.

1. Make sure that the clock is correct.
2. Put your dish into the oven and close the door.
3. Keep the key (3) pressed.
4. Press (5) or (6) keys to set the end of cooking time. Press the key with short intervals to increase or reset the time with increments of 1 minute. If you keep the key pressed, the minutes will increase and reset faster.

» **AUTO** symbol appears on the display.

5. Release the key (3).
6. Keep the key (2) pressed.
7. Press (5) or (6) keys to set the cooking time. Press the key with short intervals to increase or reset the time with increments of 1 minute. If you keep the key pressed, the minutes will increase and reset faster.
8. Release the key (2).
9. Put your dish into the oven.
10. Select operation mode and temperature.

» The oven will be heated up to the preset temperature and will maintain this temperature until the end of the cooking time you selected. The cooking symbol appears on the display during the cooking process.

11. Press the key (3) when cooking completes and the alarm sounds.
12. Turn off the oven with the Temperature knob and/or Function knob.
13. Press the key (4).

» **AUTO** symbol on the display disappears.

## Switch on semi-automatic operation

In this operation mode, oven starts cooking once you enter the cooking time.

1. Keep the key (2) pressed.
2. Press (5) or (6) keys to set the cooking time. Press the key with short intervals to increase or reset the time with increments of 1 minute. If you keep the key pressed, the minutes will increase and reset faster.

» **AUTO** symbol appears on the display.

3. Release the key (2).
4. Put your dish into the oven.
5. Select operation mode and temperature.
- » The oven will be heated up to the preset temperature and will maintain this temperature until the end of the cooking time you selected. The cooking symbol appears on the display during the cooking process.
6. Press the key (3) when cooking completes and the alarm sounds.
7. Turn off the oven with the Temperature knob and/or Function knob.
8. Press the key (4).

» **AUTO** symbol on the display disappears.



### Important

When you press key **2** during the cooking process, the display will show the remaining cooking time for a short moment.

## Stopping the cooking

1. Keep the key (2) pressed.

2. Keep the key (5) pressed until **"0.00"** appears on the display as the remaining cooking time.
  3. Release the key (2).
  4. Press the key (4).
- » **AUTO** symbol on the display disappears.
5. Turn off the oven with the Temperature knob and/or Function knob.

## How to use the program lock

### Activate the program lock

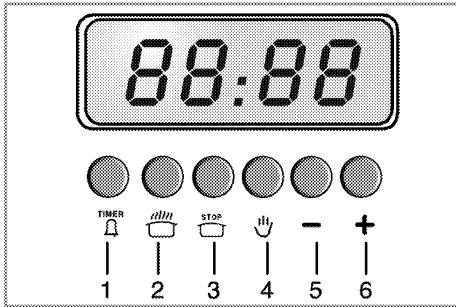

Keys:

- 1 Alarm key
  - 2 Cooking time
  - 3 End of cooking time
  - 4 Unscheduled cooking
- Time adjustment keys:
- 5 Minus key
  - 6 Plus key
1. Keep keys **1** and **2** pressed until **"ON"** appears on the display.
  2. Press key **6**.
- » The display will show **"OFF"** for some seconds. The oven is locked.

### Deactivate the program lock

1. Keep keys **1** and **2** pressed until **"OFF"** appears on the display.
2. Press key **6**.

» The display will show **"ON"** for some seconds. Now the oven can be used again.

## Using the clock as an alarm

You can use the clock of the product for any warning or reminder apart from the cooking programme.

The alarm clock has no influence on the functions of the oven. It is only used as a warning. For example, this is useful when you want to turn food in the oven at a certain point of time. Alarm clock will give a signal once the time you set is over.

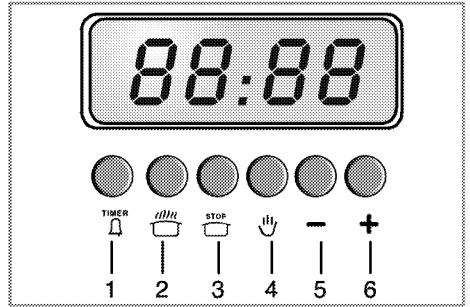

Keys:

- 1 Alarm key
  - 2 Cooking time
  - 3 End of cooking time
  - 4 Unscheduled cooking
- Time adjustment keys:
- 5 Minus key
  - 6 Plus key

### Setting the alarm clock

1. Keep Alarm key (1) pressed.



#### Important

The maximum alarm time can be 23 hours and 59 minutes.

2. Press (5) and (6) keys to determine how long after the alarm will sound.

Press the key repeatedly to increase or reset the time with increments of 1 minute. If you keep the key pressed, the minutes will increase and reset faster.

» Alarm clock symbol appears on the display.

3. Release Alarm key (1).

**i Important**  
If you press Alarm key (1) when the alarm clock is activated, remaining cooking time will be displayed briefly.

### Turning off the alarm

1. Press End of Cooking Time key (3) when the alarm sounds.

» Alarm clock symbol on the display disappears.

### If you want to cancel the alarm:

1. Keep Alarm key (1) pressed.

2. Keep the key (5) pressed until "0.00" appears on the display as the remaining time.

3. Release Alarm key (1).

» Alarm clock symbol on the display disappears.

### Cooking times table

**i Important**  
The values indicated in the table below are data indicative. They may vary according to the type of food as well as your preferences of cooking.

### Baking and roasting

**i Important**  
Level 1 is the **bottom** level in the oven.

Dish	Cooking level number	Rack position	Temperature (°C)	Cooking time (approx. in min.)
Cakes in tray*	One level	3	175	30 ... 40
	2 levels	1 - 5	175	45 ... 50
Cakes in mould*	One level	2	175	50 ... 60
Cakes in cooking paper*	One level	3	175	25 ... 35
	2 levels	1 - 5	175	35 ... 45
	3 levels	1 - 3 - 5	180	45 ... 55
Sponge cake*	One level	3	200	8 ... 15
Cookies*	One level	3	175	25 ... 30
	2 levels	1 - 5	170 ... 190	35 ... 45
	3 levels	1 - 3 - 5	175	30 ... 40
Dough pastry*	One level	3	200	35 ... 45
	2 levels	1 - 5	200	50 ... 60
	3 levels	1 - 3 - 5	200	55 ... 65
Rich pastry*	One level	3	200	25 ... 35
	2 levels	1 - 5	200	35 ... 45
	3 levels	1 - 3 - 5	190	45 ... 55
Leaven*	One level	3	200	35 ... 45
Lasagna*	One level	3	200	30 ... 40



Dish	Cooking level number	Rack position	Temperature (°C)	Cooking time (approx. in min.)
Beef steak (whole) / Roast	One level	3	25 min. 250/max, then 180 ... 190	100 ... 120
Leg of Lamb (casserole)	One level	3	25 min. 220 then 180 ... 190	70 ... 90
Roasted chicken	One level	2	15 min. 250/max, then 190	55 ... 65
Turkey (5.5 kg)	One level	1	25 min. 250/max, then 190	150 ... 210
Fish	One level	3	200	20 ... 30

When cooking with 2 trays at the same time, place the deeper tray on the upper rack and the other one on the lower rack.

\* It is suggested to perform preheating for all foods.

In a cooking that requires preheating, preheat at the beginning of cooking until the thermostat lamp turns off.

### Tips for baking cake

- If the cake is too dry, increase the temperature by 10 and decrease the cooking time.
- If the cake is wet, use less liquid or lower the temperature by 10°C.
- If the cake is too dark on top, place it on a lower rack, lower the temperature and increase the cooking time.
- If cooked well on the inside but sticky on the outside use less liquid, lower the temperature and increase the cooking time.

### Tips for baking pastry

- If the pastry is too dry, increase the temperature by 10 and decrease the cooking time. Dampen the layers of dough with a sauce composed of milk, oil, egg and yoghurt.
- If the pastry takes too long to bake, pay care that the thickness of the pastry you have prepared does not exceed the depth of the tray.
- If the upper side of the pastry gets browned, but the lower part is not

cooked, make sure that the amount of sauce you have used for the pastry is not too much at the bottom of the pastry. Try to scatter the sauce equally between the dough layers and on the top of pastry for an even browning.



### Important

Cook the pastry in accordance with the mode and temperature given in the cooking table. If the bottom part is still not browned enough, place it on one lower rack next time.

### Tips for cooking vegetables

- If the vegetable dish runs out of juice and gets too dry, cook it in a pan with a lid instead of a tray. Closed vessels will preserve the juice of the dish.
- If a vegetable dish does not get cooked, boil the vegetables beforehand or prepare them like canned food and put in the oven.

## How to operate the top oven part

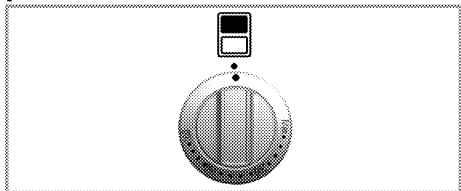

It is important to position the wire grill on wire shelf correctly. The wire grill must be placed so that it will fit into the opening of the wire shelf as illustrated in the figure.

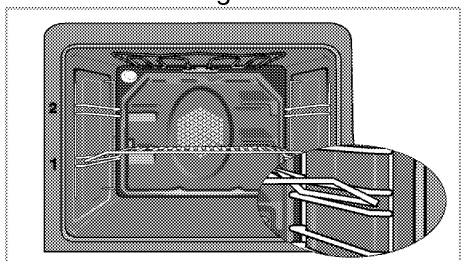

The grill oven can be used as grill or as baking oven. The oven door operates a door switch switching between grill and oven operation.

### Switch on oven

The oven is operated by means of the function knob. The oven is switched off if the function knob is in off position (top).

1. Close grill/ oven door.

2. Set oven temperature.
  - » The temperature lamp is switch off as soon as the set temperature is reached.

### Switch off grill oven

1. Turn function knob to off position (top).

### Select temperature and operating mode

1. Set the function knob to the desired temperature.
  - » The oven will heat up to and keep the set temperature. The thermostat lamp is on during heating up and down.

### Switch off electric oven

Turn function knob to off position (top).

### Cooking times table

**i Important**

The values indicated in the table below are data indicative. They may vary according to the type of food as well as your preferences of cooking.

### Baking and roasting

**i Important**

Level 1 is the **bottom** level in the oven.

Food	Cooking level number	Rack position	Temperature (°C)	Cooking time (min.) (approx.)
Cake in tray	One level	2	175	25 ... 30
Cakes in paper	One level	1	175	25 ... 30
Sponge cake	One level	2	200	5 ... 10
Cookies	One level	2	175	25 ... 30
Dough pastry	One level	2	200	35 ... 40
Filled savory pastry	One level	1	180	25 ... 35
Beefsteak (whole)/ Roast	One level	2	25 min. 250 after 180 ... 190	100 ... 120
Roast chicken (Sliced)	One level	1	15 min. 250 after 190	55 ... 65
Fish	One level	2	200	20 ... 30

## How to operate the grill -Top oven

 This product is designed for OPEN DOOR GRILLING.

 **Hot surfaces may cause burns! Children must be kept away. When the door fully open, it remains tilted slightly, so that any spillage will be directed away from you.**

 Do not use the upper level for grilling. The grill door has a door switch. As a safety feature, this switch prevents the grill from working when the door is closed.

The grill oven can be used as grill or as oven. The oven door operates a door switch switching between grill and oven operation.

 The door switch functions as a selector between the grill and electric oven feature, i.e. when the door is closed while grilling, top oven automatically switches to electric oven and **continues working**.

In order to turn off the top oven; turn top oven control knob counterclockwise to off position "O" (top).

### Switch on grill

The grill is operated by means of the function knob. The grill is switched off if the function knob is in off position "O" (top).

1. Open grill/ oven door.
2. Set grill temperature to 150 °C and preheat for around 5 minutes, if it is necessary.

3. Then set desired grill temperature.  
» The thermostat lamp is switched on.

### Switch off grill oven

1. Turn function knob to off position "O" (top).
  - Put big or medium-sized portions in correct shelf position under the grill heater for grilling.
  - Food which requires browning only should be placed under the hot grill, either in the grill pan, or on the floor of the grill compartment, according to the depth of the dish. The grill pan wire grid can be removed.
  - Plates and dishes placed on the floor of the grill compartment will be heated when main oven is in use.
  - Do not switch on the grill when using the compartment for storage.

### Electric grilling guide

- The timings in this chart are meant as a guide. Timings may vary due to starting temperature of food, thickness, type and your own preference of cooking.
- Cook only on Shelf level 1.
- If food is cooking too quickly, it can be placed in the bottom of the grill pan.
- Do not place cookware with rough bases on the oven door.
- Ensure that there is at least 25mm space at top of oven when grilling larger foods or using tall cookware.
- Always grill with the door open.
- Do not place aluminium foil on the wire rack to grill on.

- Turn food over to ensure it is cooked on both sides.
- Preheat grill first.

Food	Insertion level	Grilling time (approx.)	Preparation
Toast	1	2-4 mins	Place on wire rack in grill pan.
Bacon	1	4-6 mins	Place on wire rack in grill pan.
Gammon steaks	1	8-12 mins	Place on wire rack in grill pan.
Beefburgers	1	10-15 mins	Place on wire rack in grill pan.
Sausages	1	10-15 mins	Place on wire rack in grill pan.
Chops, chicken pieces	1	15-30 mins	Place on upturned wire rack in grill pan.
Fish fillets, fish fingers	1	10-20 mins	Place on wire rack in grill pan.
Grilling /browning tops of foods e.g. cottage pie	1	8-10 mins	Place on base of top oven.
<b># depending on thickness</b>			

## 7 Maintenance and care

### General information

Service life of the product will extend and the possibility of problems will decrease if the product is cleaned at regular intervals.



#### **DANGER**

##### **Risk of electric shock!**

Switch off the electricity before cleaning appliance to avoid an electric shock.



#### **DANGER**

##### **Hot surfaces may cause burns!**

Allow the appliance to cool down before you clean it.

- Clean the product thoroughly after each use. In this way it will be possible to remove cooking residues more easily, thus avoiding these from burning the next time the appliance is used.
- No special cleaning agents are required for cleaning the product. Use warm water with washing liquid, a soft cloth or sponge to clean the product and wipe it with a dry cloth.
- Always ensure any excess liquid is thoroughly wiped off after cleaning and any spillage is immediately wiped dry.
- Do not use cleaning agents that contain acid or chloride to clean the stainless or inox surfaces and the handle. Use a soft cloth with a liquid detergent (not abrasive) to

wipe those parts clean, paying attention to sweep in one direction.



#### **NOTICE**

The surface may get damaged by some detergents or cleaning materials.

Do not use aggressive detergents, cleaning powder/cream or any sharp objects.



#### **Important**

Do not use steam cleaners for cleaning.

### Cleaning the hob

#### **Glass ceramic surfaces**

Wipe the glass ceramic surface using a piece of cloth dampened with cold water in a manner as not to leave any cleaning agent on it. Dry with a soft and dry cloth. Residues may cause damage on the glass ceramic surface when using the hob for the next time. Dried residues on the glass ceramic surface should under no circumstances be scraped with hook blades, steel wool or similar tools. Remove calcium stains (yellow stains) by a small amount of lime remover such as vinegar or lemon juice. You can also use suitable commercially available products.

If the surface is heavily soiled, apply the cleaning agent on a sponge and wait until it is absorbed well. Then, clean the surface of the hob with a damp cloth.

**i Important**  
Sugar-based foods such as thick cream and syrup must be cleaned promptly without waiting the surface to cool down. Otherwise, glass ceramic surface may be damaged permanently.

Slight color fading may occur on coatings or other surfaces in time. This will not affect operation of the product. Color fading and stains on the glass ceramic surface is a normal condition, and not a defect.

### Cleaning the control panel

Clean the control panel and control knobs with a damp cloth and wipe them dry.

**i NOTICE**  
Damage of the control panel!  
Do not remove the control knobs for control panel cleaning.

### Cleaning the oven

No oven cleaner or any other special cleaning agent is required for cleaning the oven. It is recommended to wipe the oven with a damp cloth while it is still warm.

To clean the side wall,

1. Remove the front section of the side rack by pulling it in the opposite direction of the side wall.
2. Remove the side rack completely by pulling it towards you.

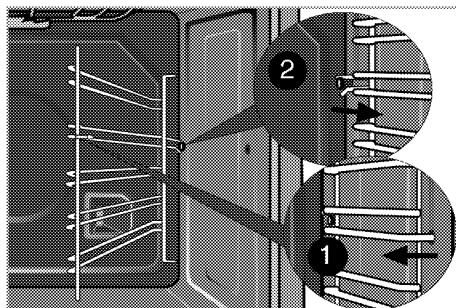

### Catalytic walls

Side walls or just back wall of oven interior may be covered with catalytic enamel.

The catalytic walls of the oven must not be cleaned. The porous surface of the walls is self-cleaning by absorbing and converting spitting fat (steam and carbon dioxide).

### Clean oven door

Don't use any harsh abrasive cleaners or sharp metal scrapers for cleaning the oven door. They could scratch the surface and destroy the glass.

### Removal of oven door

1. Open the front door.
2. Open the clips at the hinge housing on the right and left hand sides of the front door by pressing them down as illustrated in the figure.

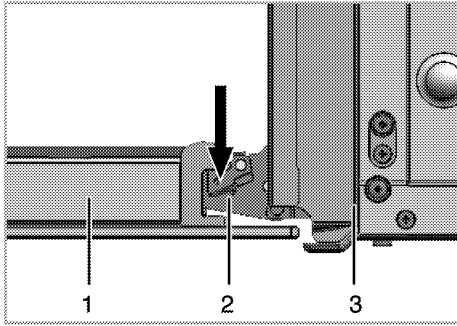

- 1 Front door
- 2 Hinge
- 3 Oven

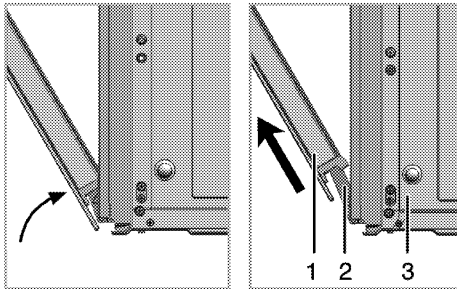

- 3. Move the front door to half-way.
- 4. Remove the front door by pulling it upwards to release it from the right and left hinges.

**i NOTICE**  
 Steps carried out during removing process should be performed in reverse order (steps 4, 3, 2 and 1) to reattach the door. Do not forget to close the clips at the hinge housing when reinstalling the door.

## Removing the door inner glass

The entire inner glass panel of the oven door can be removed for cleaning.

- Open the oven door.

- Remove the metal part (1) by removing three screws that secure it..
- To remove the plastic holders (2) , use a flat metal or plastic, e.g., a knife, slotted screwdriver, to free the fixing foot (5).

Push the fixing foot through the window (6) in arrow direction.

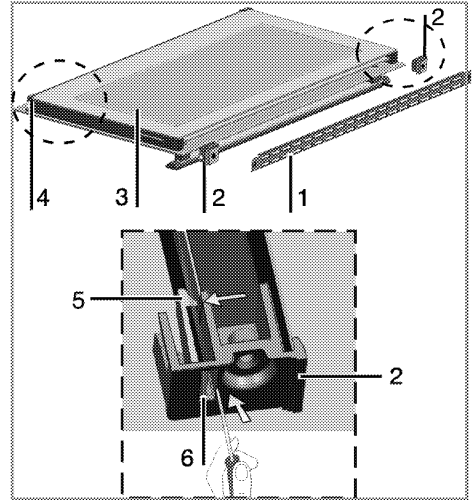

- 1 Metal part
- 2 Plastic carrier
- 3 Inner glass panel
- 4 Lower plastic slot
- 5 Fixing foot
- 6 Window

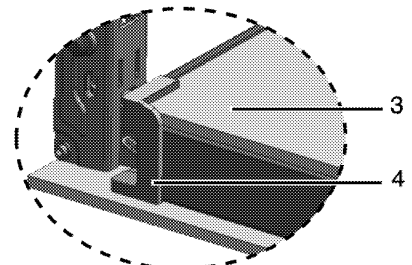

- Pull the inner glass panel (3) towards yourself until it detaches from its plastic slots (4).

- When reinstalling the glass panel, make sure that it is seated into the plastic slots.

## Replacing the oven lamp



### **DANGER**

#### **Hot surfaces may cause burns!**

Make sure that the appliance is switched off and cooled down in order to avoid the risk of an electrical shock.



### **Important**

The oven lamp is a special electric light bulb that can resist up to 300 °C. See *Technical specifications, page 5* for details. Oven lamps can be obtained from Authorised Service Agents.



### **NOTICE**

Position of lamp might vary from the figure.

### **If your oven is equipped with a round lamp:**

1. Disconnect the product from mains.
2. Turn the glass cover counter clockwise to remove it.

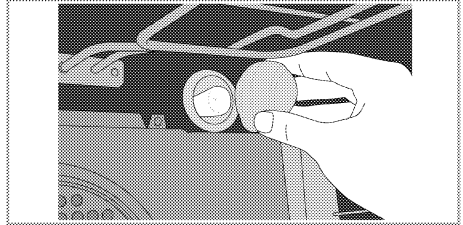

3. Remove the oven lamp by turning it counter clockwise and replace it with the new one.
4. Install the glass cover.



## 8 Troubleshooting



### DANGER

**Risk of electric shock, short circuit or fire by unprofessional repairs!**

Repairs on the appliance must be carried out by an approved service centre.

### Normal operating conditions

- Smoke and smell may emit for a couple of hours during the first operation.
- It is normal that steam escapes during operation.
- When the metal parts are heated, they may expand and cause noise.

**Before you call the service, please check the following points.**

### Electrical equipment

Malfunction/problem	Possible cause	Advice/remedy
The appliance does not work.	The mains fuse is defective or has tripped.	Check fuses in the fuse box. If necessary, replace or reset them.
	Timer buttons do not work.	Keylock may be enabled. Please disable it(See; <i>How to use the program lock, page 22</i> ).
Oven light does not work	Oven lamp is defective.	Replace oven lamp.
	No current.	Check fuses in the fuse box. If necessary, replace or reset them.
Oven does not heat.	Function knob and/thermostat knob are not set.	Set function knob and thermostat knob.
	If the appliance has a timer, the timer may not be set.	Set the time.
	No power.	Check mains supply and fuse box.

### Clock/ timer (If the appliance has a digital timer)

Malfunction/problem	Possible cause	Advice/remedy
Clock display is blinking or clock symbol is on.	Power was interrupted previously.	Set time Then switch the oven off with function knobs, set the oven function again.

If the problem has not been solved:

1. Separate unit from the mains supply (deactivate or unscrew fuse).
2. Call the after-sales service of your store reseller.



### Important

Do not attempt to repair the appliance yourself. There are no customer service items inside the appliance.

# PROOF OF PURCHASE

Proof of purchase will be required for the validation of all warranty claims. Documents suitable for proof of purchase include, but are not limited to the following:

- Delivery dockets;
- Retailer or supplier invoices;
- Credit card statements where the purchase of the appliances are clearly depicted.

The inability to provide proof of purchase will lead to the claim being treated as a service call with labour and parts costs being born by the claimant.

NOTE: There is no need to return this or any other warranty card to Electrical Distributors Australia Pty Ltd. Proof of purchase is the only requirement for warranty claim, please keep a copy of the purchase receipt with this warranty card.

## AUTHORISED SERVICE AGENTS

### NSW

ALL GENERAL WHITEGOODS  
4/11 HALLSTROM PLACE  
WETHERILL PARK 2164 NSW  
PH: 02 9756 1511  
FAX: 02 9756 1091

### VIC

MASTER TECH APPLIANCE SERVICES  
9 KIRKHAM ROAD  
DANDENONG STH VIC 3175  
PH: 1300 131 118  
FAX: 1300 366 705

### WA

DACAPS APPLIANCE PARTS AND SERVICE  
357 SEVENOAKS STREET  
CANNIGNTON WA 6107  
PH: 1800 322 277  
FAX: 1800 354 310

### SA

PRESTIGE APPLIANCE SERVICE  
UNIT 4/ 65 STEPHENS AVENUE  
TORRENSVILLE SA 5031  
PH: 08 8352 2022  
FAX: 08 8352 2044

### QLD

ENDEAVOUR REFRIGERATION  
UNIT 1/ 22 ZILLMERE ROAD  
BOONDALL QLD 4034  
PH: 07 3137 3600  
FAX: 07 3137 3663

### QLD - GOLD COAST

ROSHAD APPLIANCE SERVICE  
1/13 LEDA DRIVE  
BURLEIGH QLD 4220  
PH: 07 5535 7044  
FAX: 07 5535 7407

### TAS

FARR ELECTRICAL CONTRACTOR  
369A ARGYLE STREET  
NORTH HOBART TAS 7002  
PH: 03 6231 0275  
FAX: 03 6231 0285

**FOR OUTSIDE SERVICE AREAS PLEASE CONTACT OUR SERVICE & CARE CENTRE  
PH: 02 4920 9114**



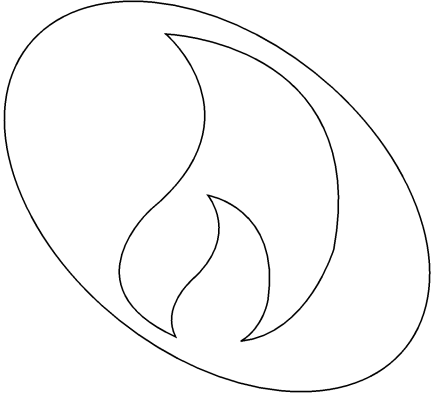

ÜAN kordul yasaqlanmas yozd

### Data Label

ÜAN kordul yasaqlanmas yozd

Printed in Turkey

Part no.

Revision no. R.AA - 27.02.2012