

## Electric Oven Radiant Coil Cooktop

## 540mm

### R54RW



features

- white enamel glass design rear controls
- 83 litre capacity electric oven
- high speed radiant coil hotplates
- removeable coils for easy cleaning
- four function oven: fan forced, defrost bottom heat, bottom heat +fan (pizza)
- closed door **separate** grill - two heights
- telescopic grill runner
- triple layer glass door
- 120 minutes mechanical timer
- cavity fan cooling system
- large viewing window
- easy clean enamel cavity
- anti-tilt bracket & stability bolt

### specifications

**Total Connected Power:** 9.37kW 39.04 amp

**Grill Power:** 1650-1800 kW

**Oven Power:** 1710-2030 kW

**Power:** 220 - 240 volt / 50 -60Hz

**Gross/net weight:** 63.5/54 kg

**Cooktop Power Total:** 6000W

Front Left: 180 mm - 2100W

Rear Left: 145 mm - 1300W

Front Right: 145 mm - 1300W

Rear Right: 145 mm -1300W

### dimensions

#### Product Dimensions

540mm (W) x 630mm (680mm including handle and knobs) (D) x 1128mm - 1168 adj (H)

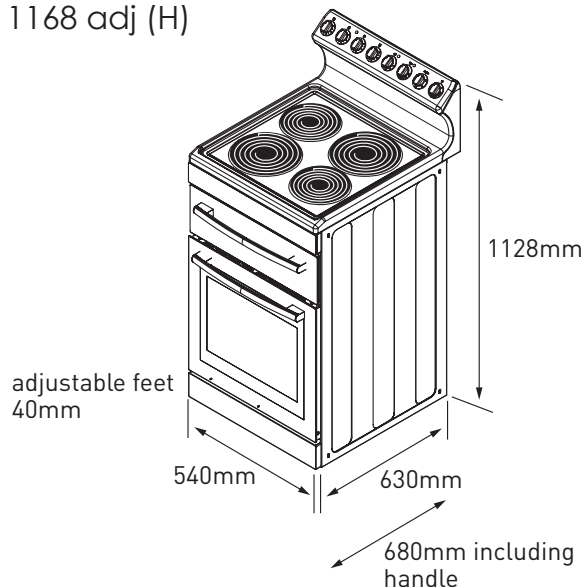

warranty - customer service



#### Customer Service

Our Nationwide Service Team can be contacted on **1800 805 300** or by logging on to

[customersupport.hapl.com.au](http://customersupport.hapl.com.au)

**HOME APPLIANCES**

20 Carlotta Street  
Artarmon NSW 2064

T: 02 9958 3111

F: 02 9958 3555

E: [info@hapl.com.au](mailto:info@hapl.com.au)

[www.euromaid.com.au](http://www.euromaid.com.au)